

**PLEASE NOTE:**

SOLID WASTE VEHICLES WEIGH APPROX. 33 TONS WHEN FULL. DRIVEWAYS MUST BE BUILT TO SUPPORT THIS WEIGHT WITHOUT DAMAGE TO DRIVE.

**HAMMER HEAD DRIVE**

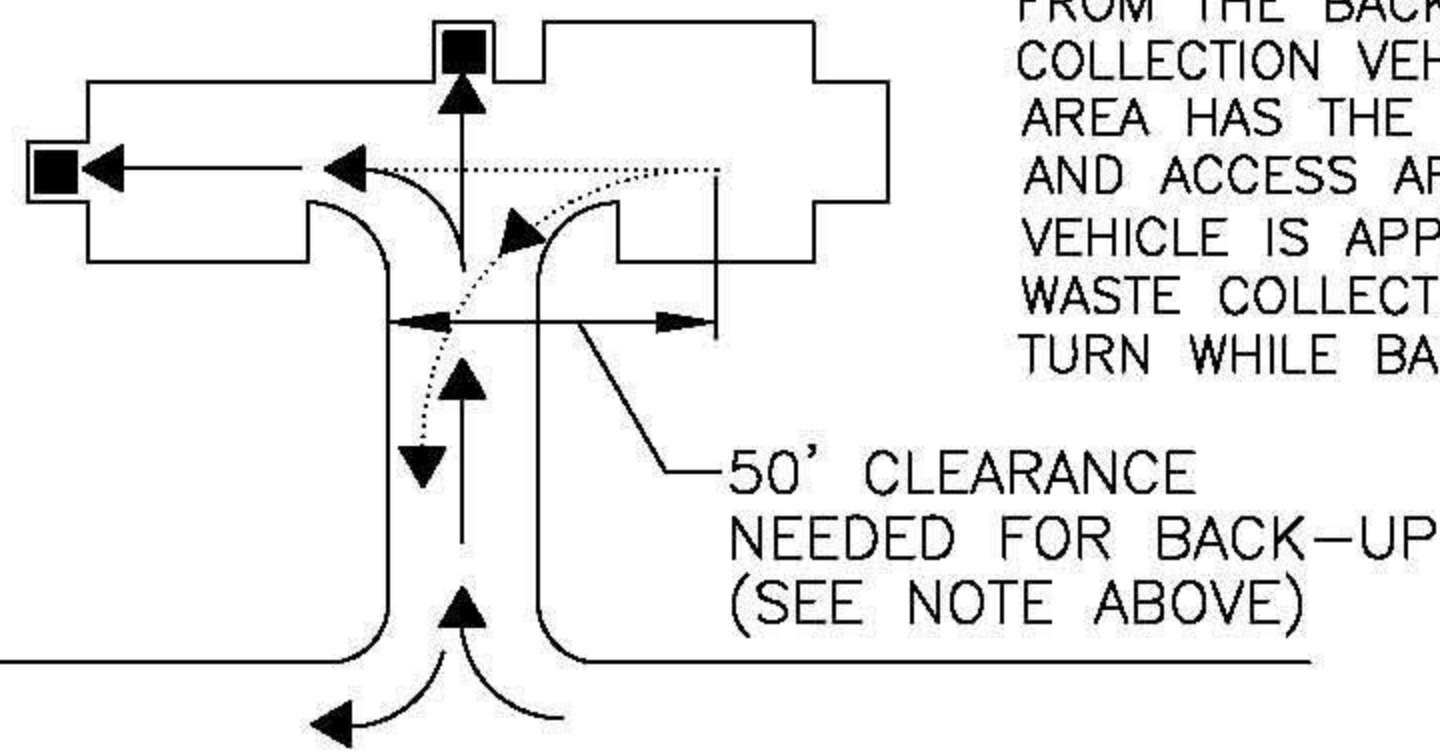

**SAFETY NOTE:**

BACKING UP MORE THAN 50' AFTER SERVICE TO A SOLID WASTE BIN IS PROHIBITED. THE 50' IS MEASURED FROM THE BACK OF THE SOLID WASTE COLLECTION VEHICLE. MAKE SURE THE AREA HAS THE PROPER TURNING RADIUS AND ACCESS AREA TO LEAVE SITE. THE VEHICLE IS APPROX. 36' LONG. SOLID WASTE COLLECTION VEHICLES WILL NOT TURN WHILE BACKING.

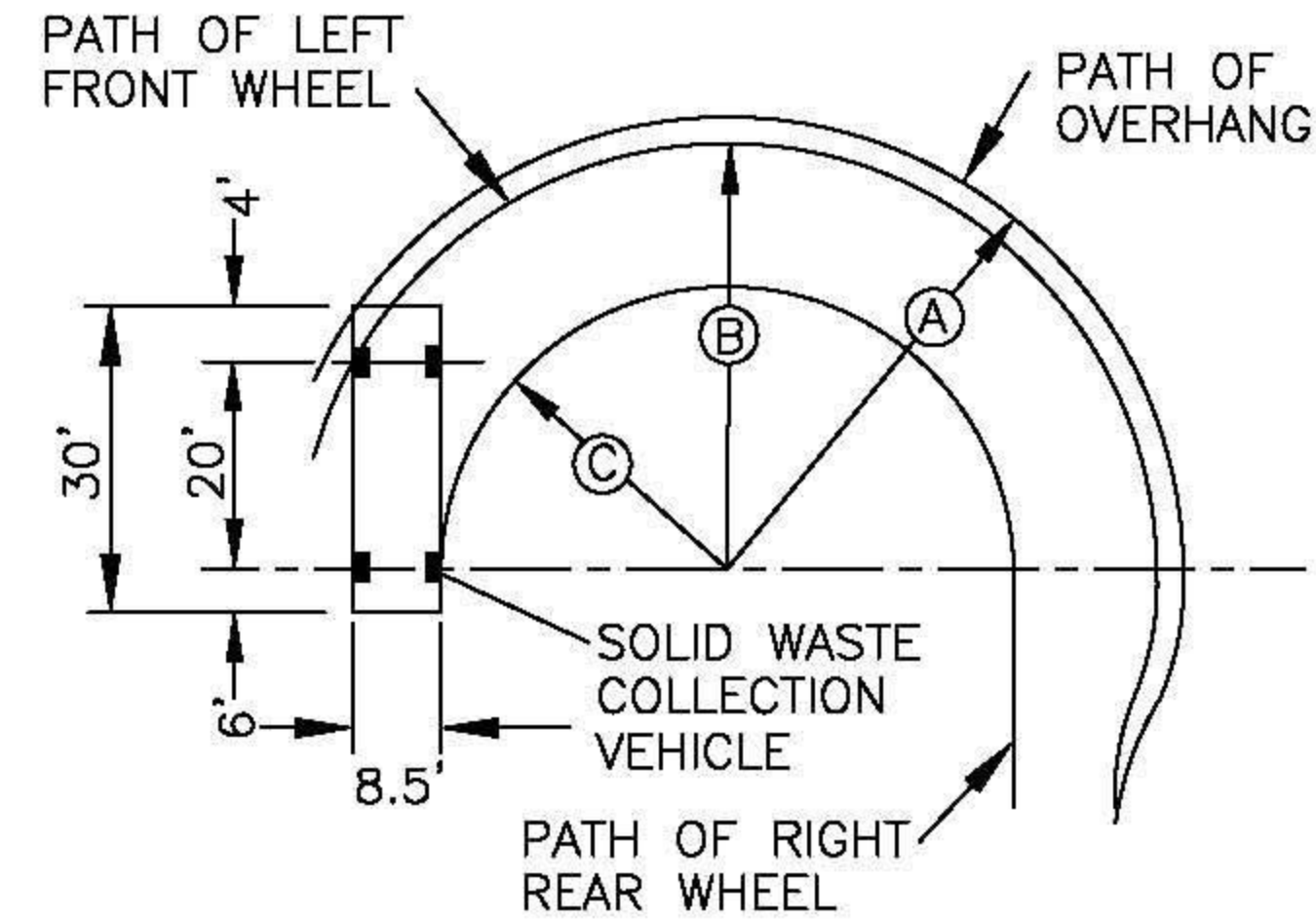

- Ⓐ 43.9' MIN. TURNING RADIUS
- Ⓑ 42' TURNING RADIUS
- Ⓒ 28.4' TURNING RADIUS

**CLEARANCE REQUIREMENTS**

**NOTES**

1. ALL CURBS ARE TO BE ALIGNED ON THE OUTSIDE OF ENCLOSURE WALLS. THE CURBS SHALL NOT INTERFERE WITH THE ROUTE OF THE SOLID WASTE COLLECTION VEHICLE.
2. IN GENERAL TERMS, ALL SOLID WASTE COLLECTION ROUTES SHALL MEET ENGINEERING DESIGN CRITERIA (STREET WIDTHS, TURNING RADII) IN A MANNER THAT ALLOWS SOLID WASTE COLLECTION VEHICLES ACCESS TO BIN ENCLOSURES. SITES SHALL BE DESIGNED SO COLLECTION VEHICLES CAN SAFELY ACCESS AND LIFT A BIN WITHOUT OBSTRUCTIONS (GROUND LEVEL AND AERIAL OBSTRUCTIONS).
3. FOR THE SAFETY OF OTHERS, SOLID WASTE COLLECTION VEHICLES WILL NOT BACK UP INTO A PUBLIC ROADWAY OR MORE THAN 50 FEET AFTER SERVICING A BIN AND WILL NOT MAKE ANY TURNS WHILE BACKING.
4. NO AWNINGS OR BUILDING PROJECTIONS ALLOWED IN SOLID WASTE COLLECTION VEHICLE ROUTES. MIN. OVERHEAD CLEARANCE OF 14' IS REQUIRED IN DRIVE AND 25' OVER BIN ENCLOSURE AREA FROM STEEL SAFETY POSTS BACK 50'.
5. ROUTES SHALL BE CLEAR OF ALL OBSTRUCTIONS (CURBS, WALLS, OVERHEAD WIRES, AND AWNINGS) TO PREVENT DAMAGE FROM THE COLLECTION VEHICLE.
6. TAKE NOTE OF THE SOLID WASTE COLLECTION ROUTE. THE COLLECTION VEHICLE SHALL TRAVEL THROUGH A SITE ONCE WITHOUT BACKTRACKING.
7. BIN ENCLOSURES ARE TO BE ANGLED NO MORE THAN 30 DEGREES FROM THE CENTER LINE OF THE SOLID WASTE COLLECTION VEHICLE ROUTE.
8. BIN ENCLOSURES SHALL BE LOCATED AWAY FROM ENTRANCES AND EXITS SO SOLID WASTE COLLECTION VEHICLE DOES NOT CREATE A SAFETY HAZARD BY BLOCKING IN-COMING OR OUT-GOING TRAFFIC.
9. STANDARDS FOR SINGLE, DOUBLE, AND TRIPLE-WIDE BIN ENCLOSURES ARE ADDRESSED ON PAGES 2 & 3

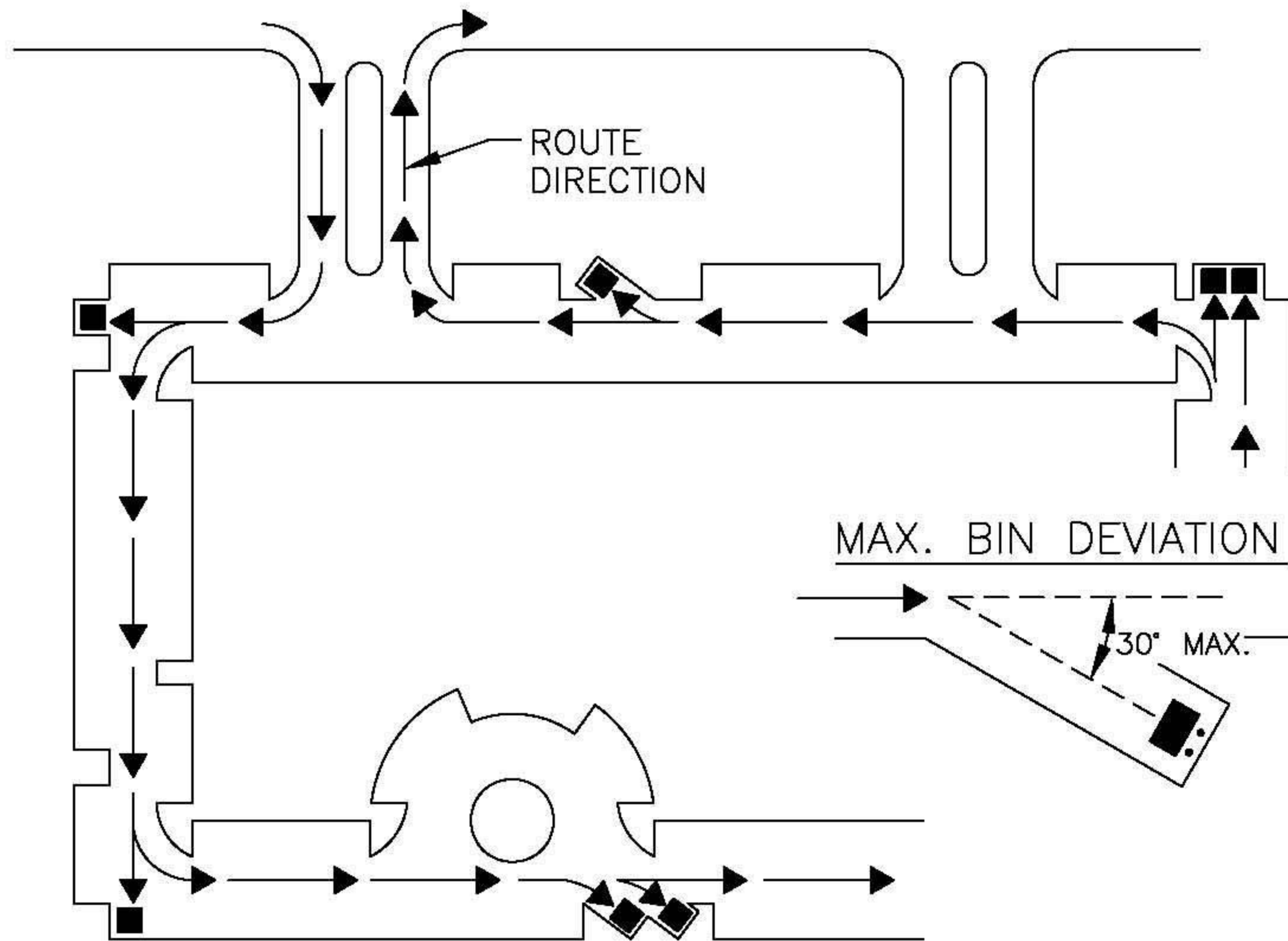

**A TYPICAL SOLID WASTE COLLECTION ROUTE**

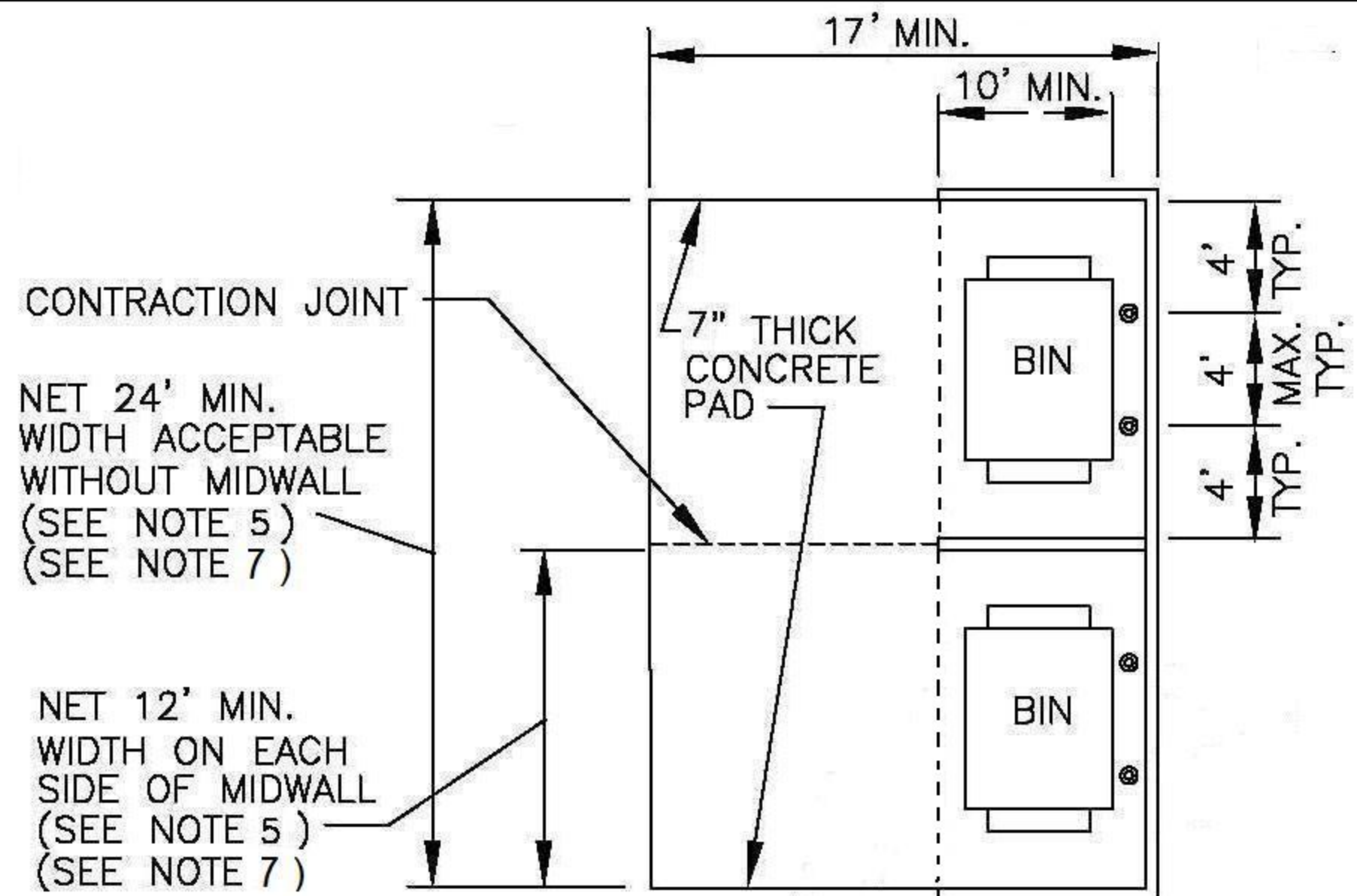

NET 12' MIN.  
WIDTH ON EACH  
SIDE OF MIDWALL  
(SEE NOTE 5)  
(SEE NOTE 7)

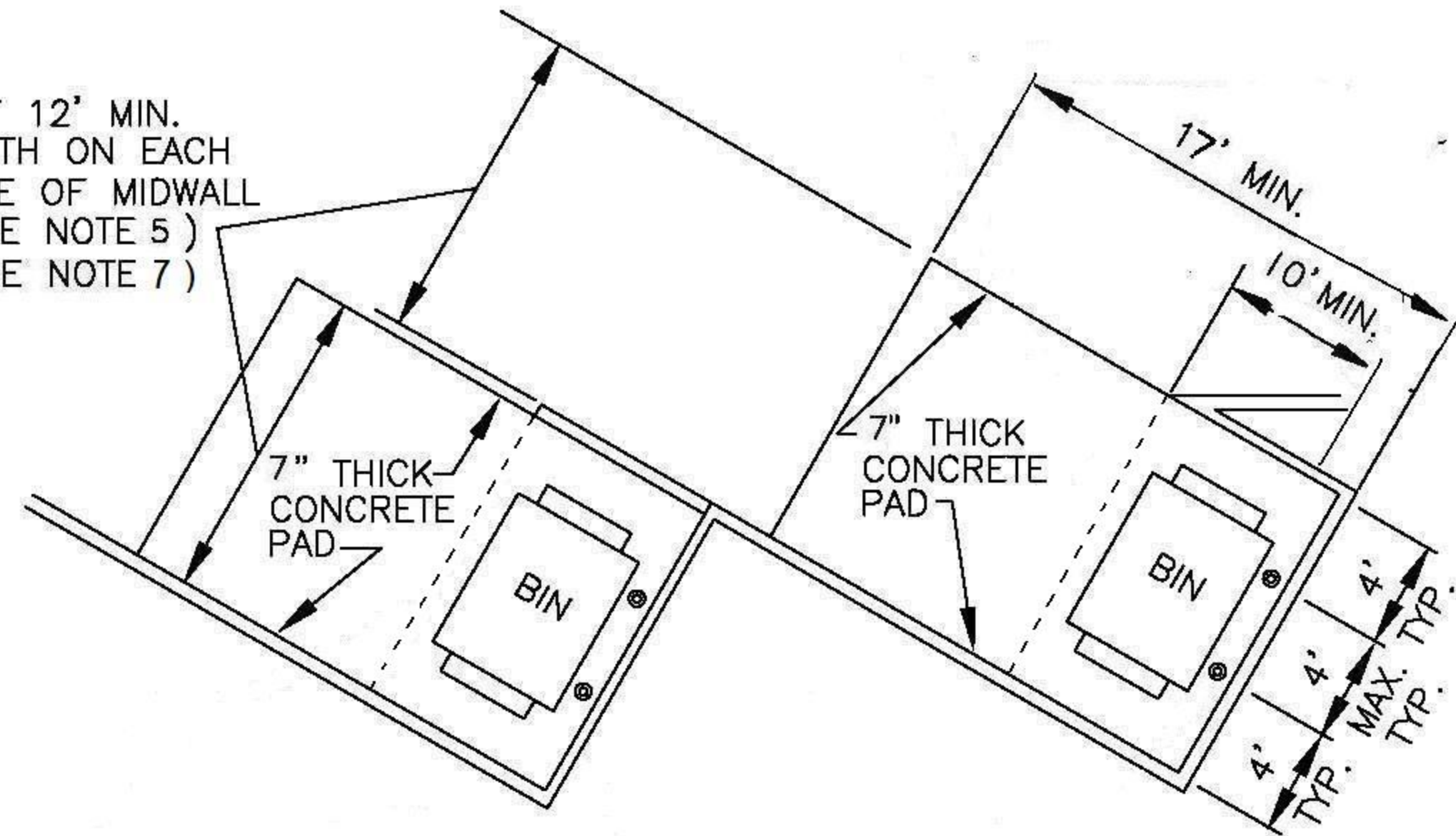

### DOUBLE WIDE BIN ENCLOSURE CONFIGURATIONS

#### NOTES

- ALL COMMERCIAL PROPERTIES SHALL BE DESIGNED WITH ENCLOSURES TO COMPLY WITH CITY OF ABILENE COMMUNITY APPEARANCE CODE SECTION 23-320.
- MULTI-UNIT RESIDENTIAL DEVELOPMENTS SHALL BE DESIGNED WITH EITHER SINGLE OR DOUBLE-WIDE ENCLOSURES FOR TRASH.
- THE NUMBER OF BIN ENCLOSURES NEEDED DEPENDS ON THE SIZE OF THE DEVELOPMENT. TYPICALLY, TOTAL VOLUME NEEDS CAN BE CALCULATED BASED ON 3 LIVING UNITS PER CUBIC YARD PER WEEK. FOR EXAMPLE; A DEVELOPMENT WITH 240 UNITS X .3 YARDS = 72 YARDS PER WEEK OR 10 TRASH BINS (8 YARD) SERVICED TWO TIMES PER WEEK
- SINGLE-WIDE BIN ENCLOSURES SHALL HAVE A NET ENCLOSURE OPENING OF 12 FEET.
- DOUBLE-WIDE BIN ENCLOSURES SHALL HAVE A NET ENCLOSURE OPENING OF 24 FEET WITHOUT MIDWALLS. ALTHOUGH NOT PREFERRED, DOUBLE WIDE BIN ENCLOSURES CAN BE DESIGNED WITH MIDWALLS WITH A NET ENCLOSURE OPENING OF 12 FEET ON EACH SIDE OF MIDWALL.
- GATES, HINGES, & MOUNTING HARDWARE SHALL BE INSTALLED SO THERE IS A MIN. 10 FOOT DEPTH CREATED WITHIN EACH ENCLOSURE.
- GATES, HINGES, AND MOUNTING HARDWARE SHALL NOT INTRUDE UPON MINIMUM NET ENCLOSURE OPENING.
- GATES MUST BE ABLE TO BE SECURED IN THE OPEN POSITION.
- BIN ENCLOSURES ARE TO BE ANGLED NO MORE THAN 30 DEGREES FROM THE CENTER LINE OF THE SOLID WASTE COLLECTION VEHICLE ROUTE.
- BINS THAT ARE VISIBLE FROM A PUBLIC ROADWAY SHALL HAVE ENCLOSURE GATES THAT SCREEN THE BINS FROM PUBLIC VIEW.
- BIN ENCLOSURES TO BE A MINIMUM OF 3 FEET FROM ANY NON-COMBUSTIBLE PLANNED OR EXISTING STRUCTURE AT ITS CLOSEST POINT; 5 FEET FROM ANY COMBUSTIBLE PLANNED OR EXISTING STRUCTURE AT ITS CLOSEST POINT (PER UNIFORM FIRE CODE 1103.2.2).
- STANDARDS FOR SOLID WASTE VEHICLE ACCESS ARE ADDRESSED ON PAGE 1.
- STANDARDS FOR TRIPLE WIDE ENCLOSURES ARE ADDRESSED ON PAGE 3.
- RESTAURANTS MUST PROVIDE A SEPARATE ENCLOSED AREA TO ACCOMMODATE THEIR GREASE TRAP. THIS DESIGNATED AREA MUST NOT INTERFERE WITH THE TRASH/RECYCLING COLLECTION.
- SOLID WASTE ENCLOSURES MAY INCLUDE WATER CONNECTIONS & DRAINS TO FACILITATE CLEANING OF DUMPSTERS. THESE SHOULD BE LOCATED TO NOT IMPEDE THE ENCLOSURE OPENING (AND GATING IF REQUIRED). ADDITIONAL ITEMS SUCH AS LANDSCAPING CONTROL BOXES AND LIGHTING MAY BE POSITIONED ON THE OUTSIDE OF THE ENCLOSURE WALLS.
- A MINIMUM CLEARANCE OF 2' MUST BE MAINTAINED AROUND ANY CONTAINER.

#### MAX. BIN DEVIATION

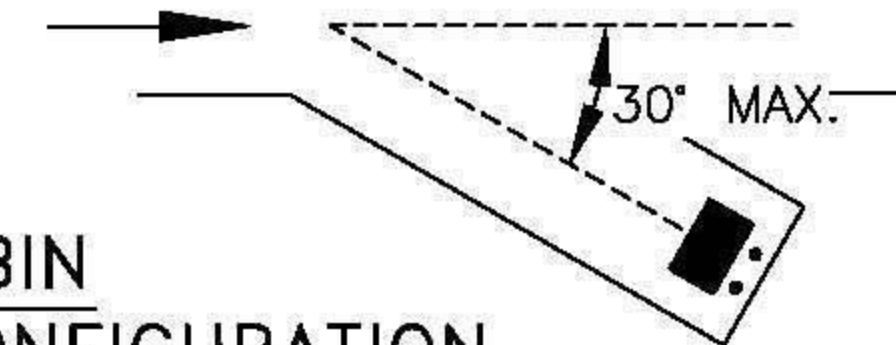

#### SINGLE-WIDE BIN ENCLOSURE CONFIGURATION

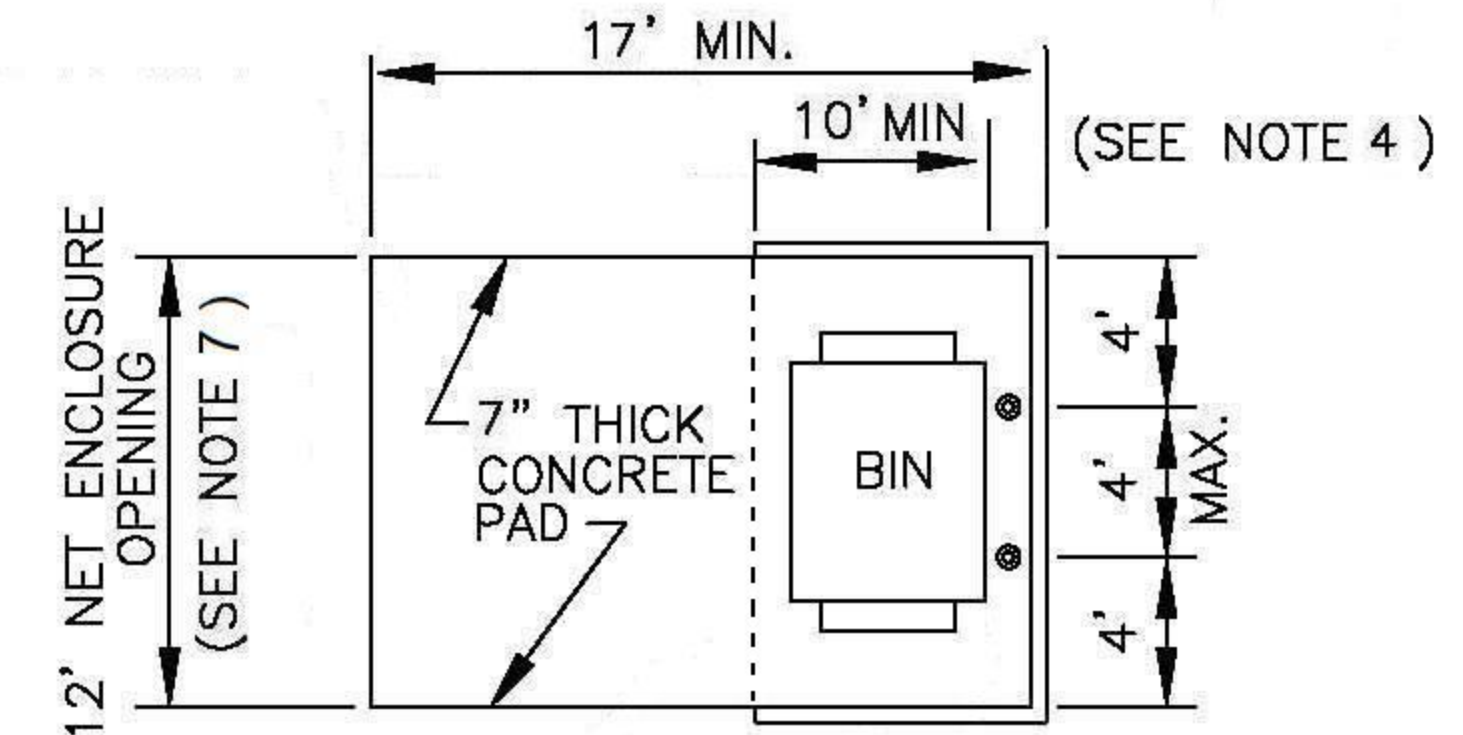

DRAWINGS ARE NOT TO SCALE

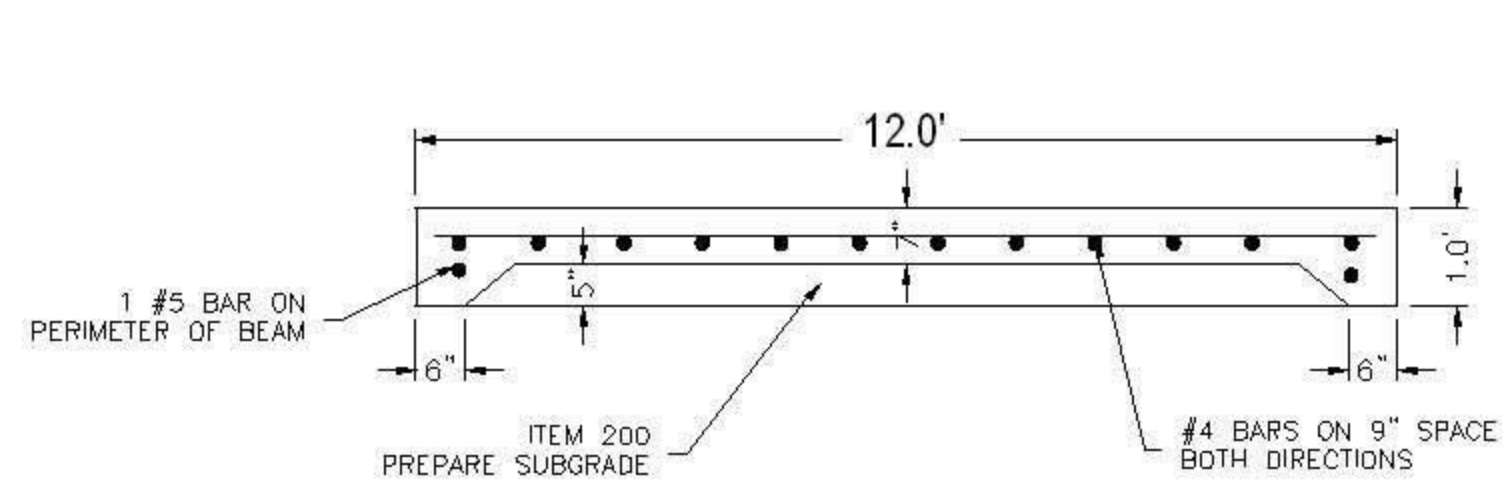

Reinforced steel concrete pad for truck tires and one steel container requires a 12' x 17' x 7" pad. Add 12' in width for each additional container. Require #4 rebar on 9" spacing in both directions. The subgrade shall be 6" of density compacted soil or 6" of flexible base compacted to density.

Shown above are basic planning sizes. Approach distances and angle requirements must be coordinated with our Commercial Supervisors (325-676-6054) prior to construction.

Concrete shall be 6 sack per C.Y. or equivalent Item 360 modified for Concrete Pavement. The subgrade will be prepared and approved by 95% density compaction requirements.

**NOTES**

1. TRIPLE-WIDE ENCLOSURES SHALL HAVE A NET ENCLOSURE OPENING OF 36 FEET AND SHALL BE DESIGNED WITHOUT MIDWALLS. GATES, HINGES, AND MOUNTING HARDWARE SHALL NOT INTRUDE UPON MINIMUM NET ENCLOSURE OPENING.
2. GATES, HINGES, AND MOUNTING HARDWARE SHALL BE INSTALLED SO THERE IS A MINIMUM 10 FOOT DEPTH CREATED BETWEEN GATES AND BOLLARDS.
3. BIN ENCLOSURES ARE TO BE ANGLED NO MORE THAN 30 DEGREES FROM THE CENTER LINE OF THE SOLID WASTE COLLECTION VEHICLE ROUTE.
4. CONTRACTION JOINTS MAY BE EITHER SCORED OR SAWCUT TO A DEPTH OF D/3.

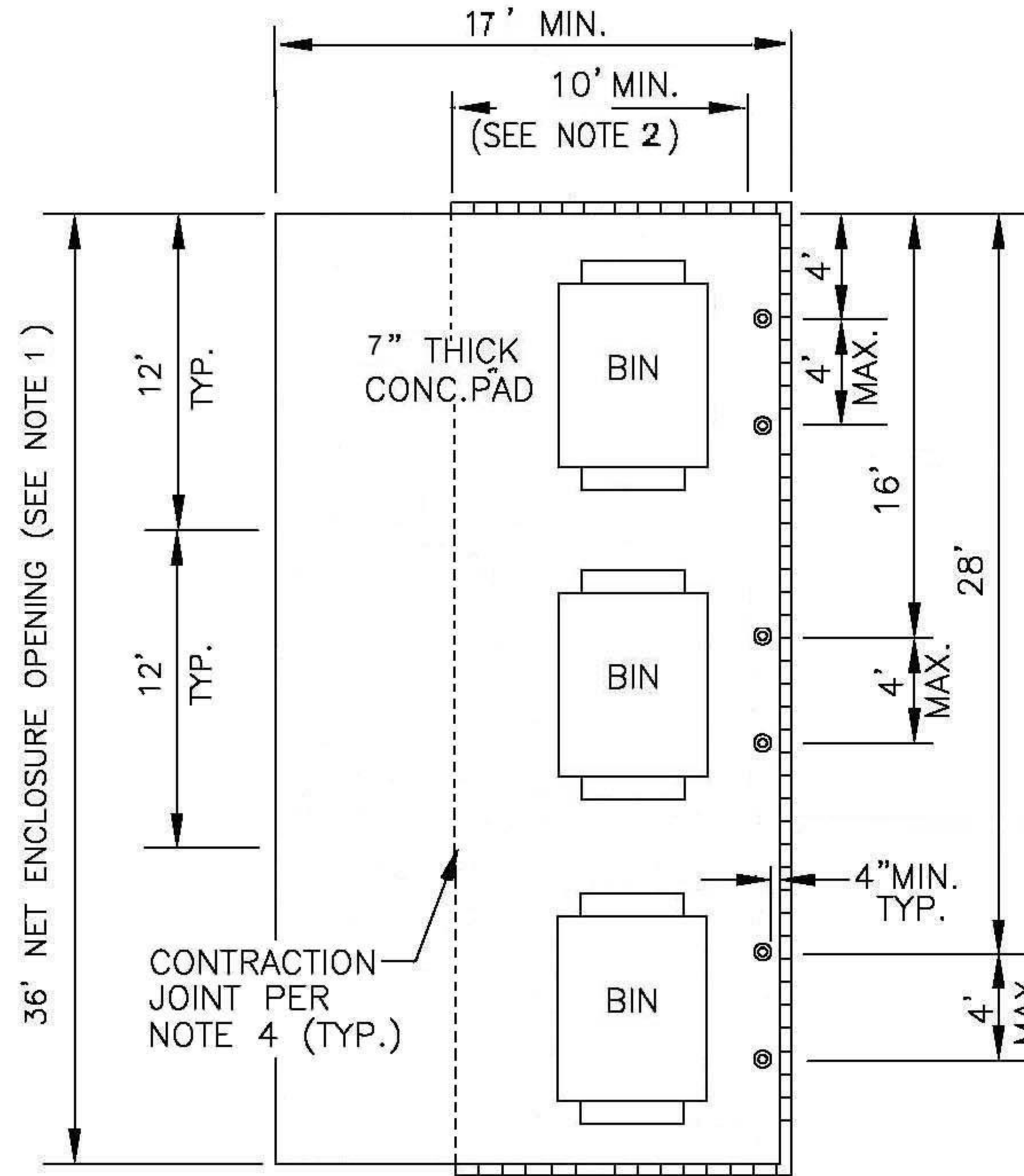

TRIPLE-WIDE BIN ENCLOSURE